



**MANUAL DE MONTAGEM  
ASSEMBLY INSTRUCTIONS  
INSTRUCCIONES DE MONTAJE**

**COD BR: BC 96**



# Sumário Summary Resumen

Introdução Introduction Introducción	.....	3
Antes de começar Before starting Antes de comenzar	.....	4
Evite acidentes Avoid accidents Evitar accidentes	.....	4
Dimensões e ferramentas Dimensions and tools Dimensiones y herramientas	.....	5
Identificação das peças Identifying parts Identificación de las piezas	.....	6
Acessórios incluídos na caixa Hardware included in box Accesorios incluidos en la caja	.....	7
Montagem do móvel Furniture assembly Montaje del mueble	.....	8

## Introdução Introduction Introducción

Leia atentamente este manual e siga os passos indicados para que o produto não perca a garantia e também para uma perfeita montagem.

Read this manual and follow the steps in order to keep the guarantee and also for the perfect fit.

Lea este manual y siga los pasos para que el producto no pierda la garantía y también para el ajuste perfecto.

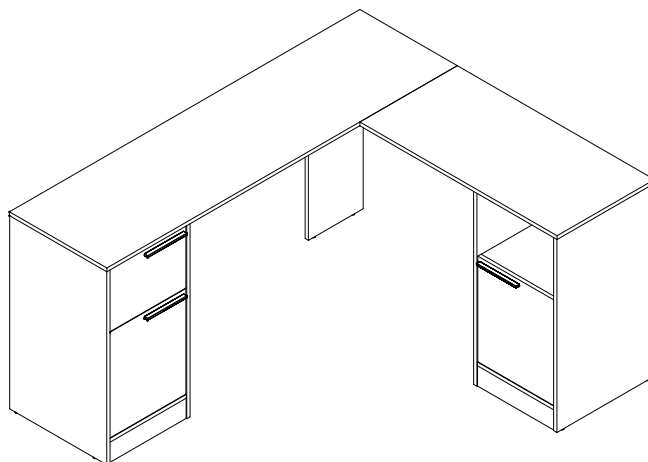

## Antes de começar Before starting Antes de comenzar

Antes de começar a montagem prepare o ambiente, deixando-o completamente limpo e com bom espaço para iniciar o trabalho.

Prepare the room before starting the assembly, leaving it completely clean and the area in good condition to start the work.

Antes de comenzar el montaje preparar el ambiente, dejándolo completamente limpio y con bueno espacio para comenzar el trabajo.

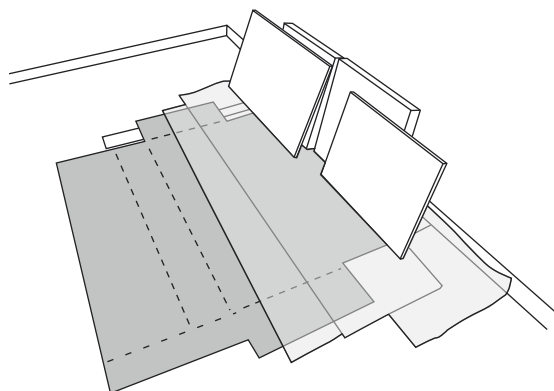

Utilize o papelão da própria embalagem para separar e apoiar as peças retiradas das caixas.

Use the cardboard of the packaging to separate and support the parts removed from the boxes.

Utilice el cartón de la embalaje para separar y apoyar las piezas desmontadas de las cajas.



Forre a área de montagem com um cobertor ou tapete. Assim, você evita avarias nas peças durante o processo de montagem.

Cover the assembly area with a blanket or carpet to avoid damaging the parts during the assembly process.

Cubrir la zona de ensamble con una manta o alfombra. De este modo, se evitan daños en las piezas durante el proceso de montaje.



## Evite acidentes Avoid accidents Prevenir accidentes

Solicitamos observar atentamente as orientações de montagem como: fixação do produto na parede, colocação de cola em locais específicos necessários, o peso suportado pelo produto, etc...

We request you to carefully observe the assembly instructions as: fixing the product on the wall, adding glue in needed and specific places, product weight limit, etc.

Pedimos que lea atentamente las instrucciones, principalmente las informaciones de fijación del producto en la pared, colocación de pegamento en local específico y necesario, el peso soportado por el producto etc...

Não escale ou se apoie no móvel.

Do not climb or lean on the furniture.

No se suba ni se apoye en el mueble.



Dimensões e ferramentas  
Dimensions and tools  
Dimensiones y herramientas

Dimensões:

L: 1600 A: 785 P: 1345 mm

Dimensions:

W: 62.99 H: 30.90 D: 52.95 inches

Dimensiones:

L: 1600 A: 785 P: 1345 mm

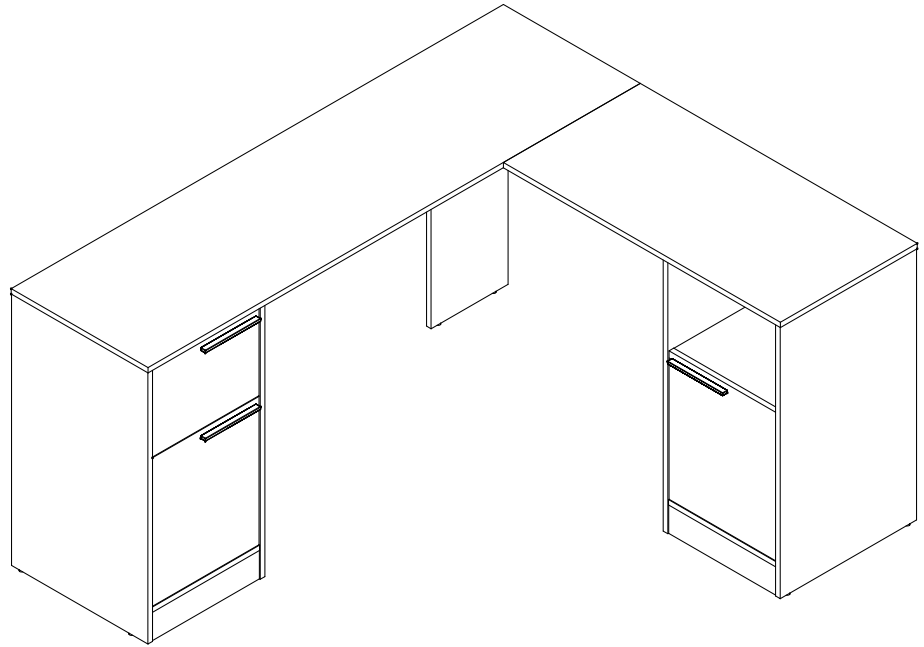

Limpeza  
Cleaning  
Limpieza

Pano levemente umedecido com água, seguido de pano seco, não utilizar produtos químico ou abrasivos.  
You can clean the product with slightly dampened cloth followed by a dry cloth. Do not use chemicals or abrasives.  
Solamente utilizar un paño húmedo y después un paño seco, no utilice productos químicos o abrasivos.

Todas as peças do móvel foram marcadas com um número. Antes de começar a montagem, identifique as peças numeradas em relação às instruções de montagem. Uma vez concluída a montagem, os números podem ser facilmente removidos com um pano ligeiramente embebido em álcool. Use álcool apenas para remover números das peças.

All the furniture parts have been marked with a number. Before you start assembling, please identify the numbered parts in relation to the assembly instructions. Once assembly is completed, the numbers can be easily removed with a cloth slightly damped in alcohol. Use alcohol only to remove part numbers.

Todos las piezas del mueble fueron marcadas con un número. Antes de empezar el montaje, identifique las piezas numeradas en relación con las instrucciones de montaje. Una vez que se completa el armado, los números se pueden quitar fácilmente con un paño ligeramente empapado en alcohol. Use alcohol solo para eliminar números de las piezas.

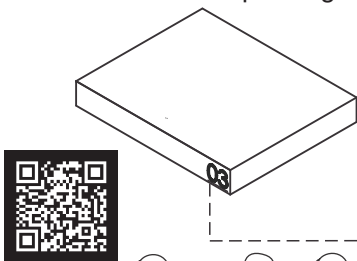

**UTILIZE ALCOOL APENAS PARA REMOVER O NUMERO DAS PEÇAS**  
**USE ALCOHOL ONLY TO REMOVE PART NUMBERS**  
**UTILICE ALCOHOL SOLAMENTE PARA ELIMINAR EL NUMERO DE LAS PIEZAS**

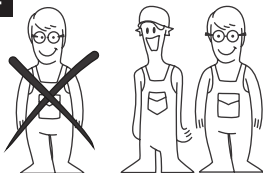

Para facilitar a montagem, utilize uma parafusadeira elétrica.  
To speed assembly, use an electronic screwdriver.  
Para facilitar el armado, utilice un destornillador eléctrico.

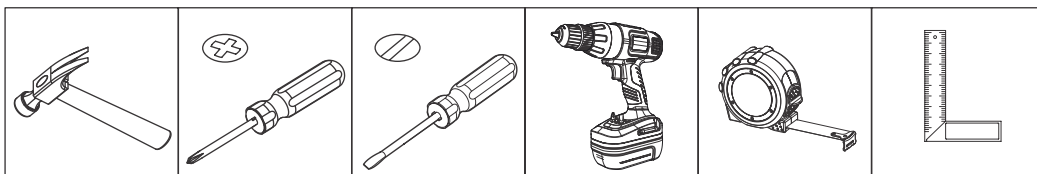

# COD BR: BC 96

PEÇA	DESCRIÇÃO	QUANT.	PART	DESCRIPTION	QTY	PIEZA	DESCRIPCIÓN	CANTIDAD
001	TAMPO	1	001	TOP	1	001	TAPA	1
002	TAMPO MENOR	1	002	LOWER TOP	1	002	TAPA MENOR	1
003	LATERAL ESQUERDA	1	003	LEFT SIDE	1	003	LATERAL IZQUIERDA	1
004	DIVISÓRIA ESQUERDA	1	004	LEFT PARTITION	1	004	PARTICIÓN IZQUIERDA	1
005	DIVISÓRIA DIREITA	1	005	RIGHT PARTITION	1	005	PARTICIÓN DERECHA	1
006	LATERAL DIREITA	1	006	RIGHT SIDE	1	006	LATERAL DERECHA	1
007	PRATELEIRA SUPERIOR	2	007	UPPER SHELF	2	007	REPISA SUPERIOR	2
008	PRATELEIRA INFERIOR	2	008	LOWER SHELF	2	008	REPISA INFERIOR	2
009	COSTA MENOR	1	009	LOWER BACK	1	009	REVÉS MENOR	1
010	COSTA MAIOR	1	010	LONGER BACK	1	010	REVÉS MAYOR	1
011	LATERAL MENOR	1	011	LOWER SIDE	1	011	LATERAL MENOR	1
012	PORTA DIREITA	1	012	RIGHT DOOR	1	012	PUERTA DERECHA	1
013	PORTA ESQUERDA	1	013	LEFT DOOR	1	013	PUERTA IZQUIERDA	1
014	FRENTE DE GAVETA	1	014	DRAWER'S FRONT	1	014	FRENTE CAJÓN	1
015	RODAPÉ	2	015	BASEBOARD	2	015	RODAPIE	2
016	FUNDO DE GAVETA	1	016	DRAWER'S BOTTOM	1	016	FONDO CAJÓN	1
017	COSTA MAIOR	2	017	LONGER BACK	2	017	REVÉS MAYOR	2
018	COSTA MENOR	1	018	LOWER BACK	1	018	REVÉS MENOR	1
020	LATERAL DE GAVETA DIREITA	1	020	DRAWER'S RIGHT SIDE	1	020	LATERAL DERECHA CAJÓN	1
021	COSTA DE GAVETA	1	021	DRAWER'S BACK	1	021	REVÉS CAJÓN	1
022	LATERAL DE GAVETA ESQUERDA	1	022	DRAWER'S LEFT SIDE	1	022	LATERAL IZQUIERDA CAJÓN	1

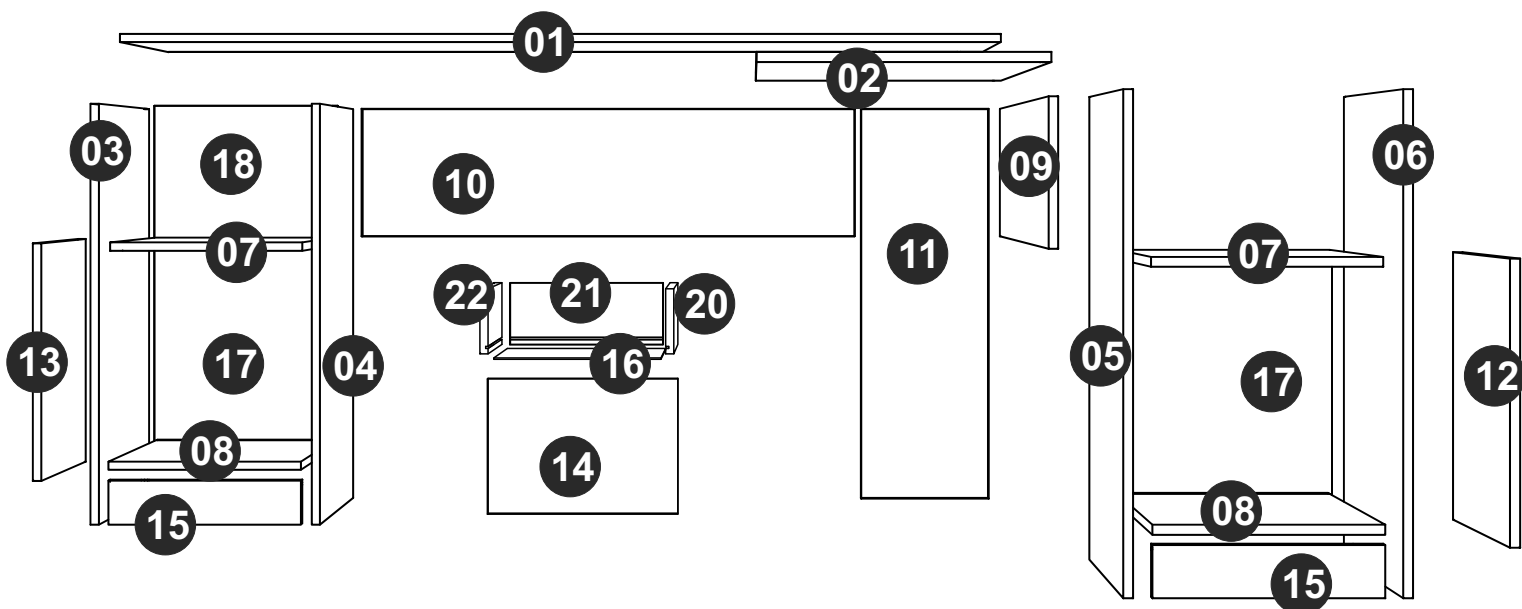



EF 000033x 40  
8x30



EF 000751 X 2



EF 000094 X 35



EF 000106 X 40  
3,5x14 CC



EF 000107 x 4  
3,5X16 CC

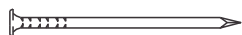

EF 000168 X 60  
10X10 C/C



EF 000216 X 39



EF 000381 x 6  
3X25 CC



EF 000724x 2  
8x40

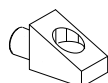

EF 000714 X 4

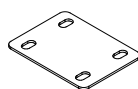

EF 000069 X 2



SUPORTE ANGULAR X 4  
ANGULAR SUPPORT X 4  
SOPORTE ANGULAR X 4

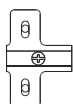

EF 000025 X 4

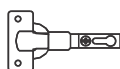

EF 000043 X 4



CORREDIÇA x 2  
DRAWER TRAKS x 2  
CORREDERAS x 2



GIZ x 01  
CHALK x 01  
TIZA x 01

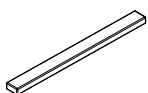

PUXADOR x 3  
HANDLE x 3  
MANIJA x 3



PÉS REDONDOS x 10  
ROUND FEET x 10  
PIES REDONDOS x 10

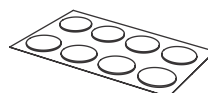

TAPA FUROS x 39  
STICKER x 39  
TAPAS PLÁSTICAS x 39

Utilize para medir as ferragens.

Utilice para medir el herraje.

Use for measuring the hardware.

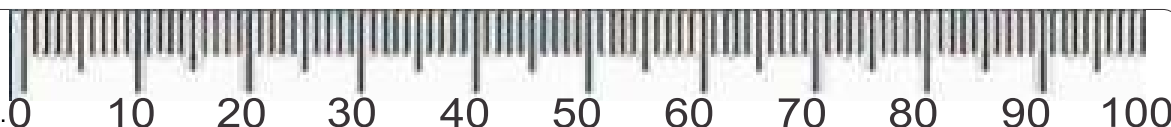

**Garantia (exclusivo para o Brasil/exclusivo de Brasil/exclusive to Brazil):**

A garantia dos produtos fabricados pela BRV Móveis, abrange eventuais defeitos-vícios de fabricação, no prazo estabelecido pelo código de Defesa do Consumidor, em seu artigo 26.II. o qual prevê a garantia de 90 (noventa) dias.

**A** = 25KG - 55.11LB

**B** = 14KG - 30.86LB

**C** = 5KG - 11.02LB

**D** = 2KG - 4.40LB

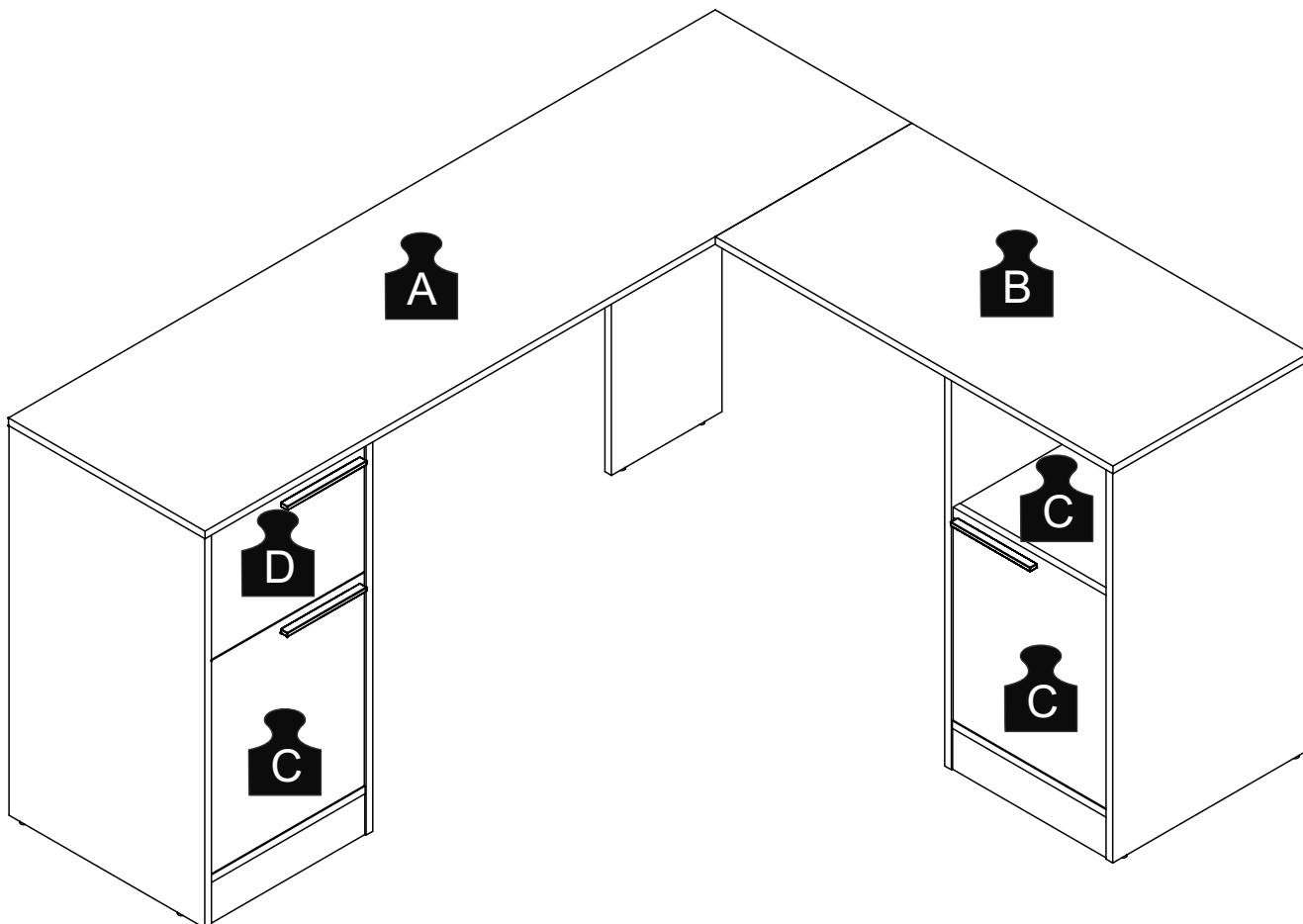

**PASSO 1 / STEP 1 / PASO 1**

Fixe a ferragem EF 000094 nas peças 01, 02, 14, 20 e 22.  
Fix hardware EF 000094 in pieces 01, 02, 14, 20 and 22.  
Fije el herraje EF 000094 en las piezas 01, 02, 14, 20 y 22.

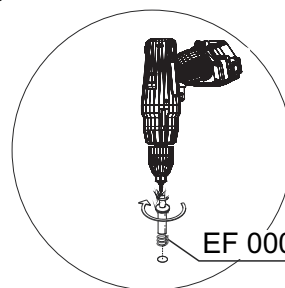
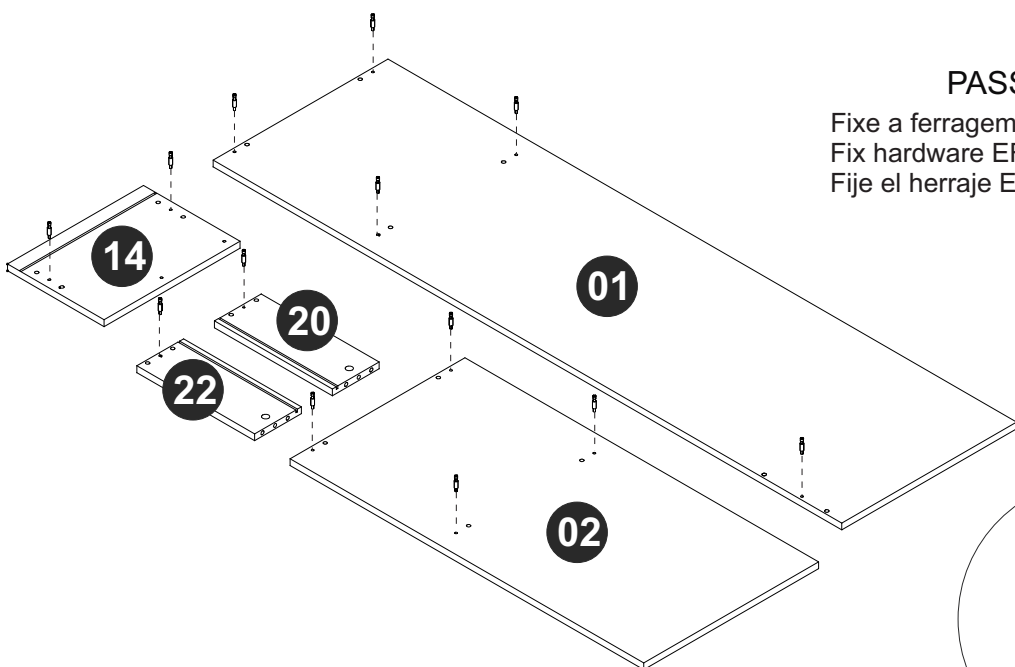



## PASSO 2 / STEP 2 / PASO 2

Fixe os pés, utilizando a ferragem EF 000168, e a ferragem EF 000094 nas peças 03, 04, 05, 06 e 11. Insira a ferragem EF 000714 nas peças 03, 04, 05 e 06.  
Attach the feet, using hardware EF 000168, and hardware EF 000094 in pieces 03, 04, 05, 06 and 11. Insert hardware EF 000714 in pieces 03, 04, 05 and 06.  
Fije los pies, utilizando el herraje EF 000168, y el herraje EF 000094 en las piezas 03, 04, 05, 06 y 11. Añade el herraje EF 000714 en las piezas 03, 04, 05 y 06.

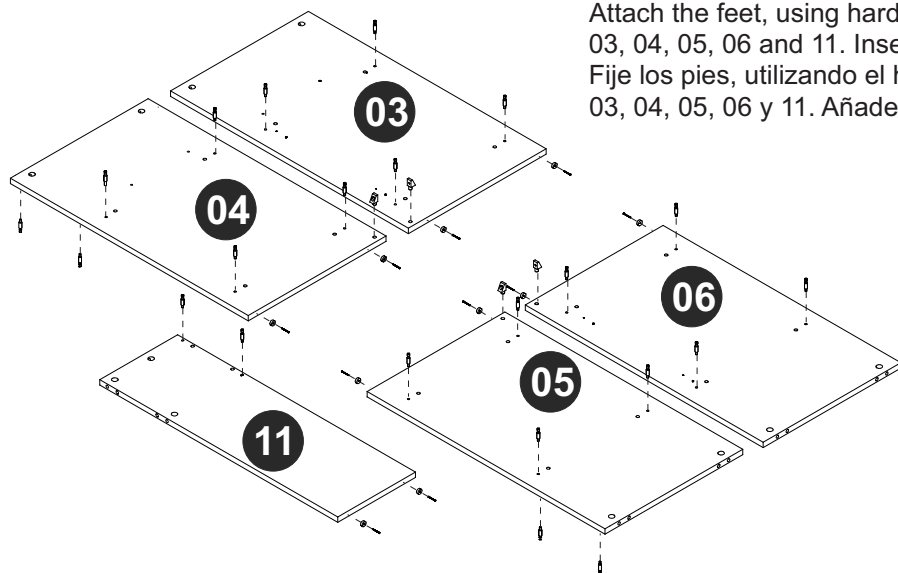

Pés redondos  
Round feet  
Pies redondos

EF 000168

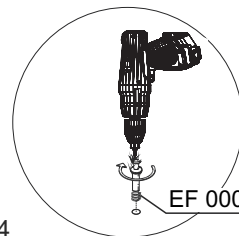
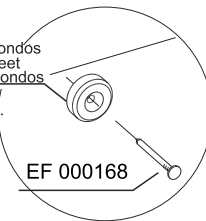

EF 000094

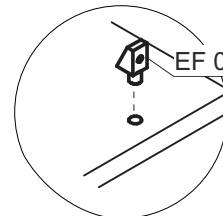

EF 000714



## PASSO 3 / STEP 3 / PASO 3

Insira a ferragem EF 000033 nas peças 07, 08, 09, 10, 11, 20, 21 e 22.  
Insert the hardware EF 000033 into pieces 07, 08, 09, 10, 11, 20, 21 and 22.  
Añade el herraje EF 000033 en las piezas 07, 08, 09, 10, 11, 20, 21 y 22.

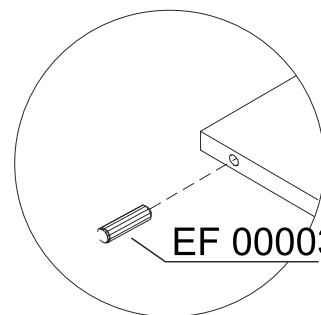
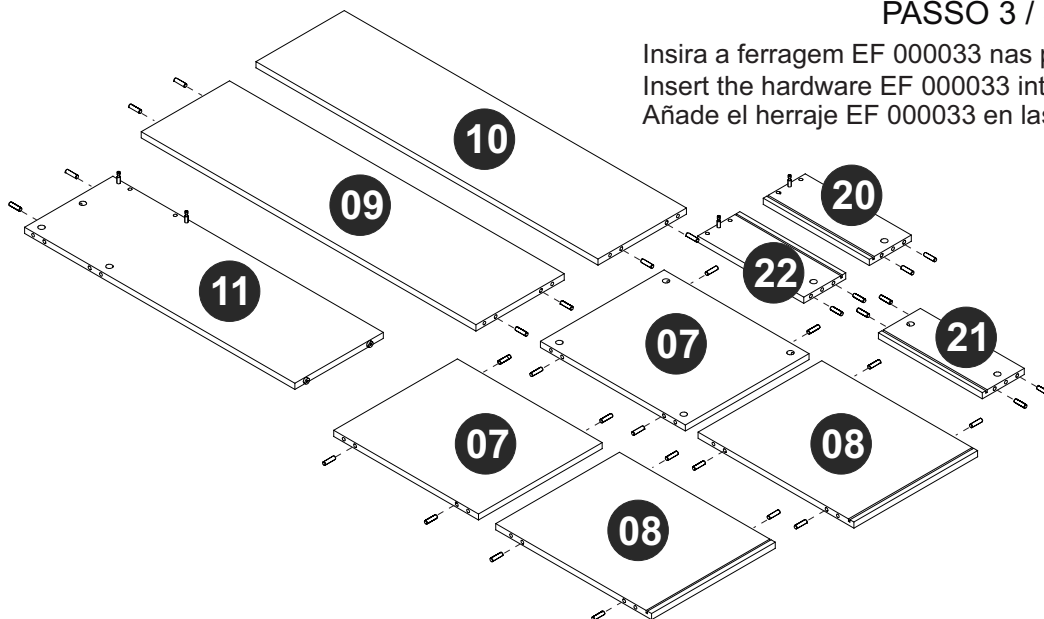

EF 000033

## PASSO 4 / STEP 4 / PASO 4

Insira a ferragem EF 000033 nas peças 03, 04, 05 e 06. Fixe as corrediças utilizando a ferragem EF 000106 nas peças 03 e 04.  
Insert hardware EF 000033 into pieces 03, 04, 05 and 06. Attach the drawer tracks using hardware EF 000106 into pieces 03 and 04.  
Añade el herraje EF 000033 en las piezas 03, 04, 05 y 06. Fije las correderas utilizando el herraje EF 000106 en las piezas 03 e 04.

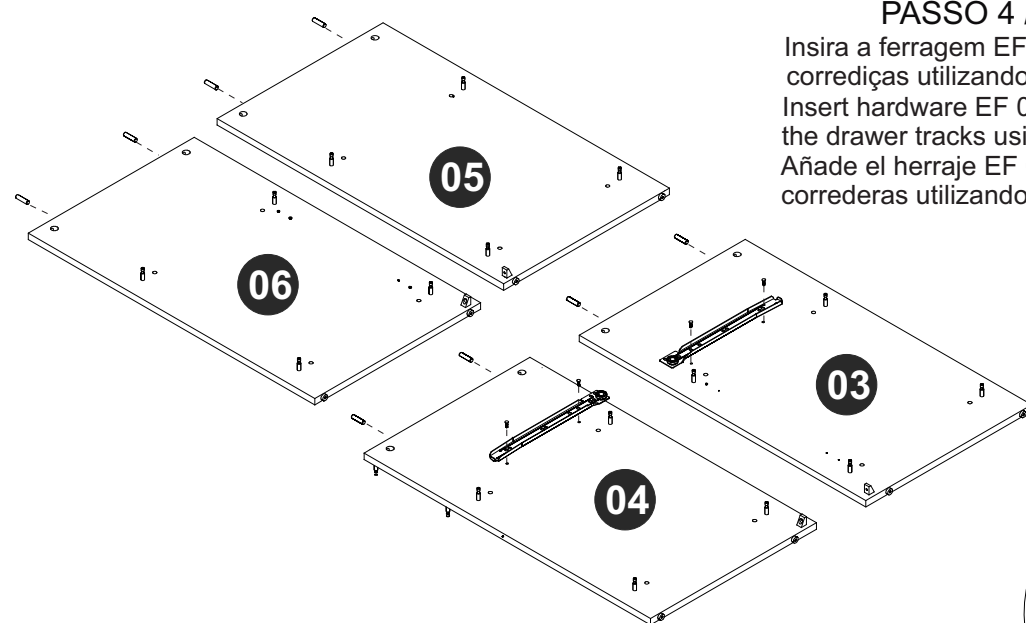

EF 000106

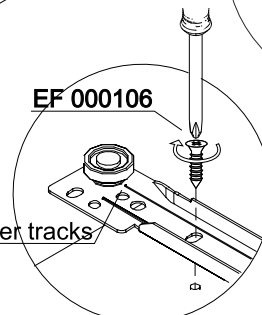

Corrediça/Corredera/Drawer tracks

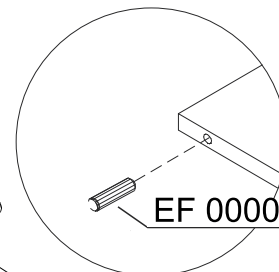

EF 000033



## PASSO 5 / STEP 5 / PASO 5

Use a ferragem EF 000106 para fixar o suporte angular na ranhura das peças 15 e fixar a ferragem EF 000025 nas peças 03 e 06.  
Use hardware EF 000106 to attach the angular support in pieces 15 and attach hardware EF 000025 into pieces 03 and 06.  
Utilice el herraje EF 000106 para fijar el soporte angular en las piezas 15 y fijar el herraje EF 000025 en las piezas 03 y 06.

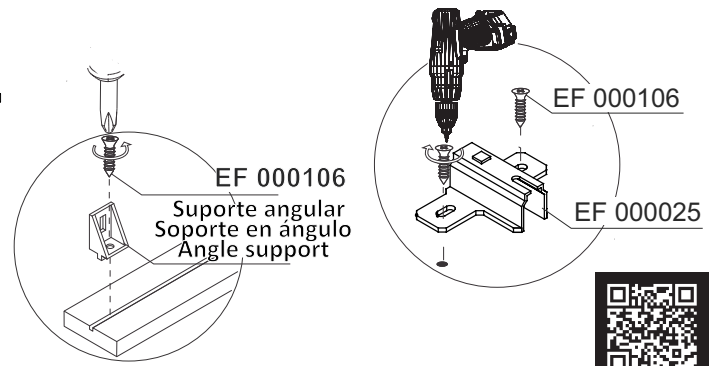
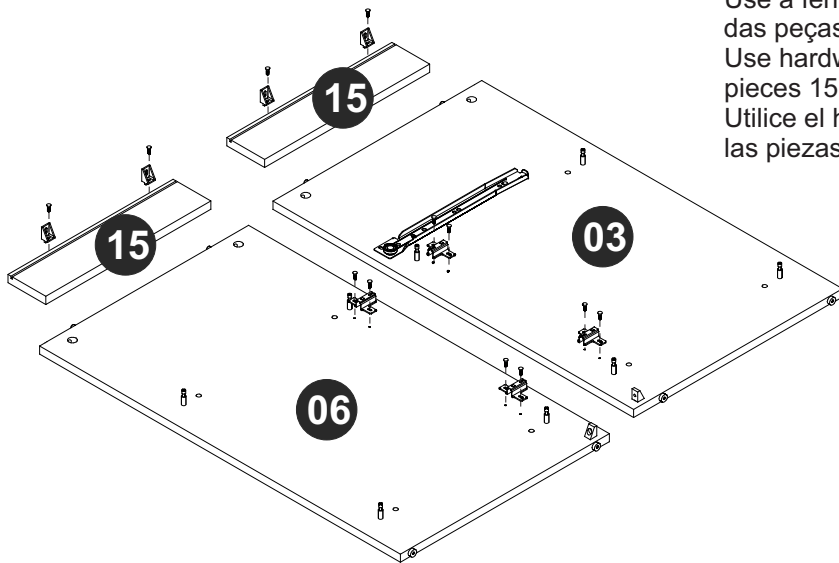

## PASSO 6 / STEP 6 / PASO 6

Fixe a ferragem EF 000043 usando a ferragem EF 000106 e o puxador usando a ferragem EF 000381 nas peças 12 e 13.  
Fix the hardware EF 000043 using hardware EF 000106 and the handle using hardware EF 000381 to pieces 12 and 13.  
Fije el herraje EF 000043 utilizando el herraje EF 000106 y la manija utilizando el herraje EF 000381 en las piezas 12 y 13.

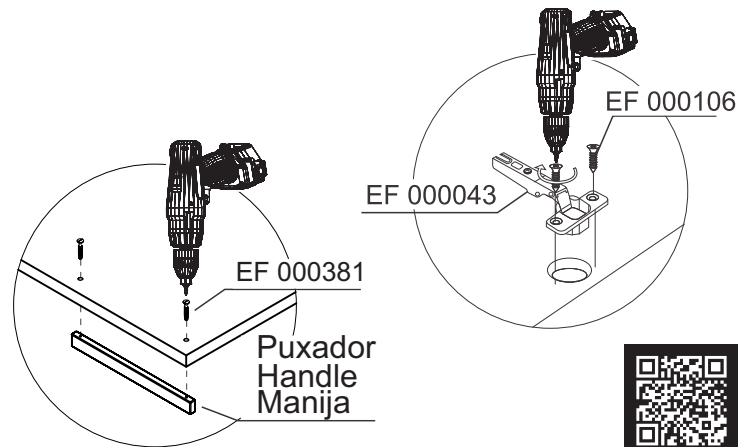
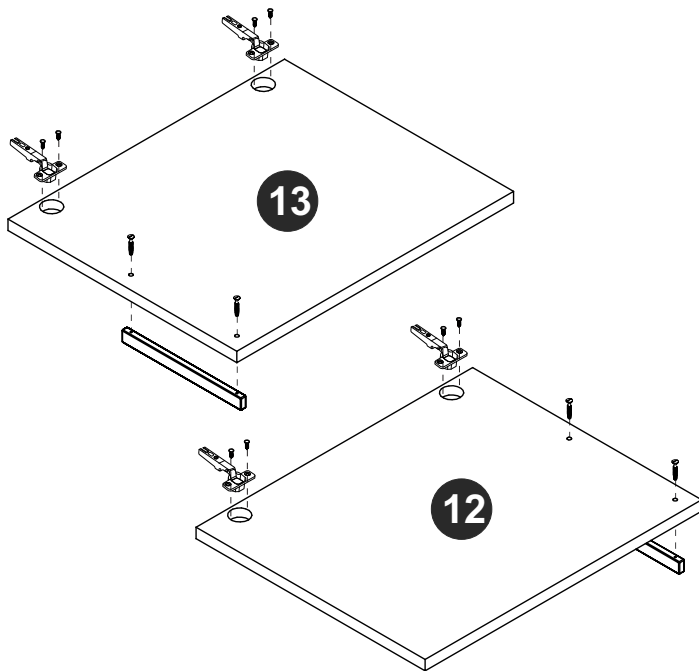

## PASSO 7 / STEP 7 / PASO 7

Conecte as peças 03, 04, 07 e 08, insira a ferragem EF 000216 e gire para apertar.  
Connect pieces 03, 04, 07 and 08, insert hardware EF 000216 and turn to tighten.  
Junte las piezas 03, 04, 07 y 08, añada el herraje EF 000216 y gire para apretar.

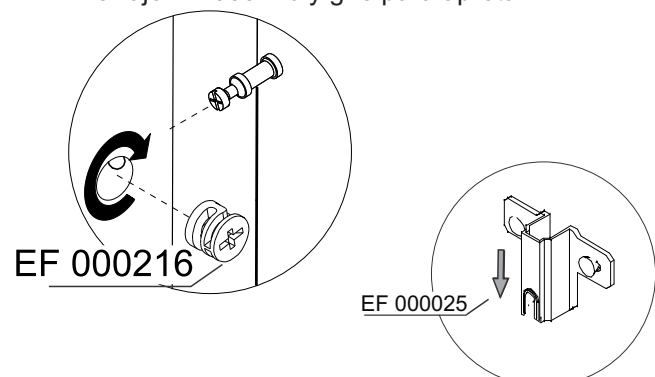
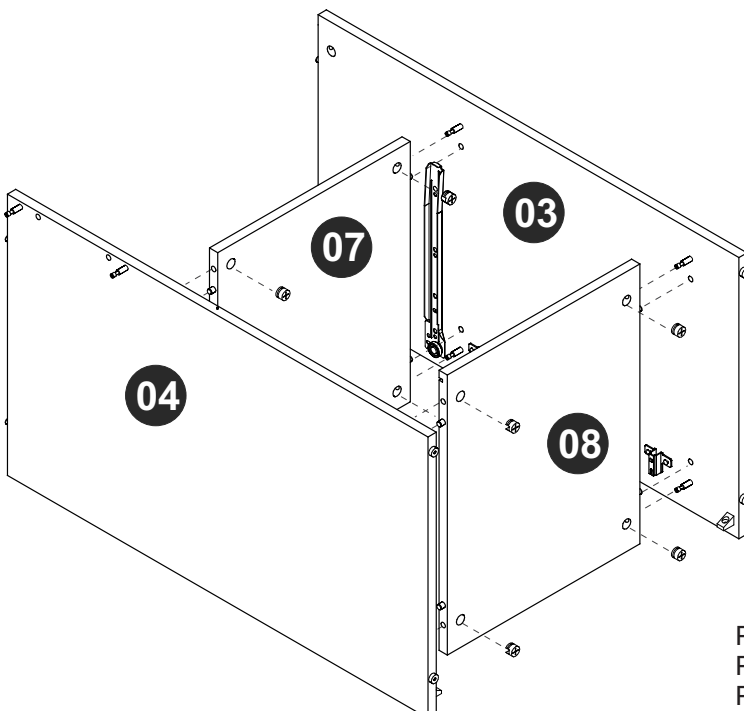

Por favor, observe a posição da ferragem EF 000025.  
Please, note hardware EF 000025 position.  
Por favor, notar la posición del herraje EF000025.

### PASSO 8 / STEP 8 / PASO 8

Conecte a peça 15 utilizando as ferragens EF 000106 e EF 000107.  
Connect piece 15 using hardware EF 000106 and EF 000107.  
Junte la pieza 15 utilizando los herrajes EF 000106 y EF 000107.

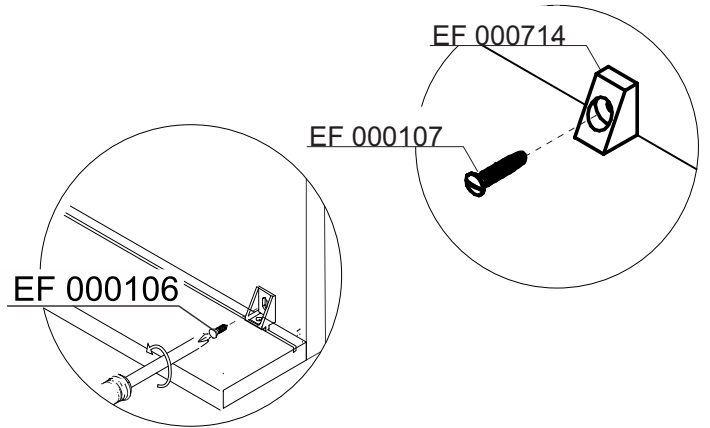
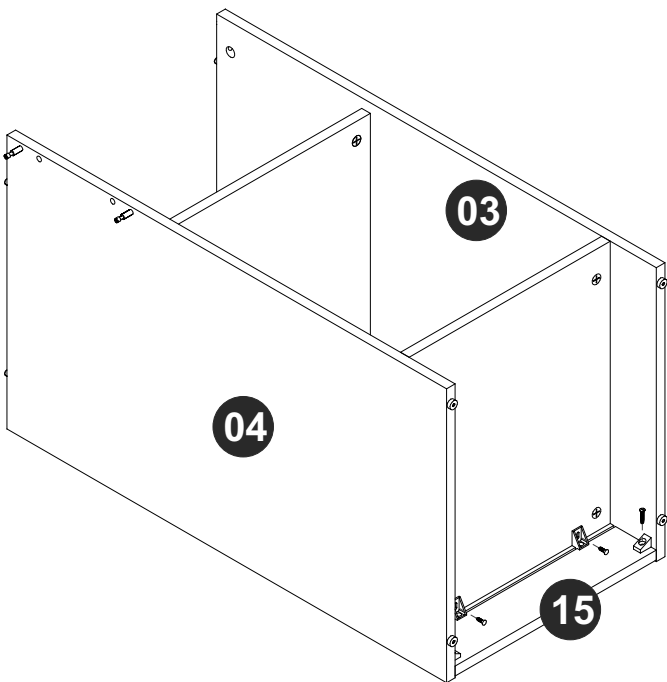

### PASSO 9 / STEP 9 / PASO 9

Fixe as peças 17 e 18 utilizando a ferragem EF 000168.  
Fix the pieces 17 and 18 using hardware EF 000168.  
Fije las piezas 17 y 18 utilizando el herraje EF 000168.

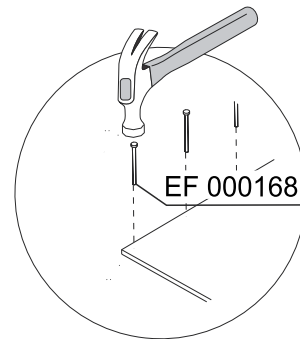
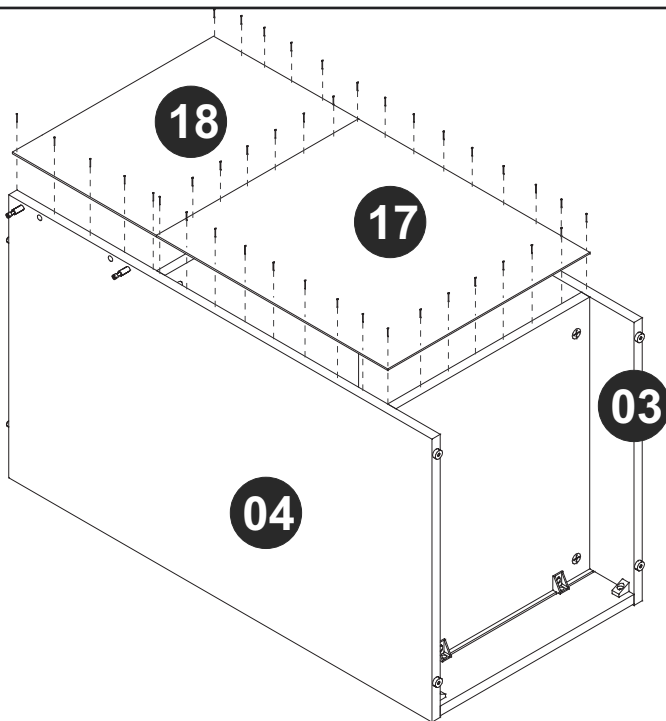

Por favor, note a posição das corrediças  
Please, note the drawer tracks position  
Por favor, notar la posición de las correderas

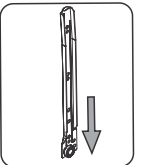

### PASSO 10 / STEP 10 / PASO 10

Insira as ferragens EF 000751 e EF 000724 na peça 11. Conecte as peças 04, 10 e 11, insira a ferragem EF 000216 e gire para apertar.  
Insert hardware EF 000751 and EF 000724 into piece 11. Connect pieces 04, 10 and 11, insert hardware EF 000216 and turn to tighten.  
Añade los herrajes EF 000751 y EF 000724 en la pieza 11. Junte las piezas 04, 10 y 11, añade el herraje EF 000216 y gire para apretar.

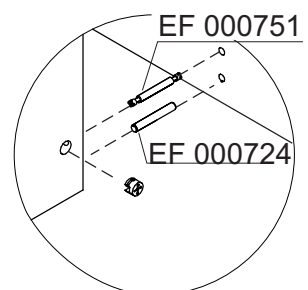
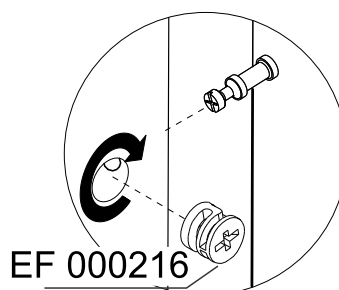
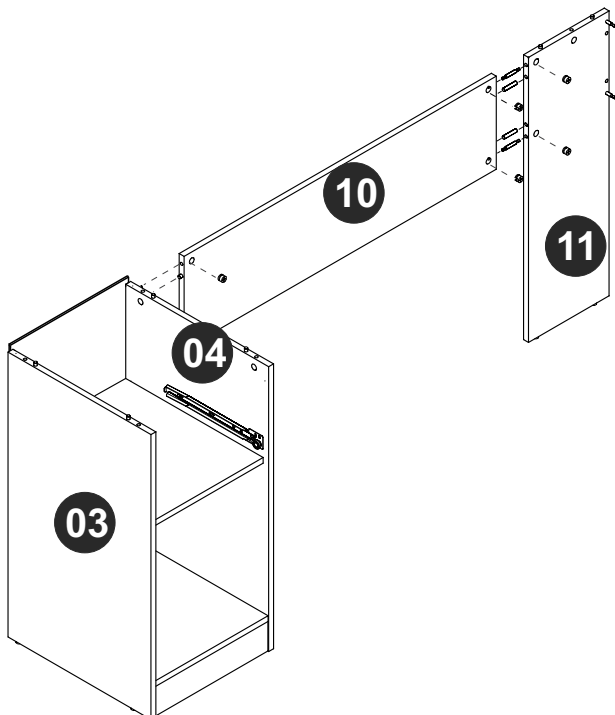

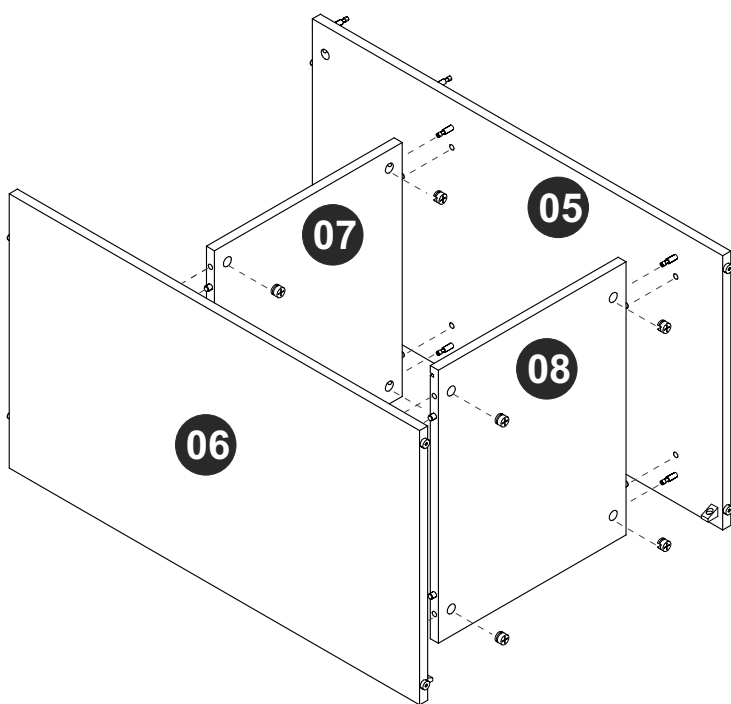

**PASSO 11 / STEP 11 / PASO 11**

Conecte as peças 05, 06, 07 e 08, insira a ferragem EF 000216 e gire para apertar.  
 Connect pieces 05, 06, 07 and 08, insert hardware EF 000216 and turn to tighten.  
 Junte las piezas 05, 06, 07 y 08, añade el herraje EF 000216 y gire para apretar.

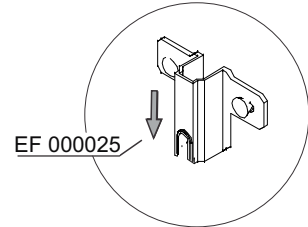
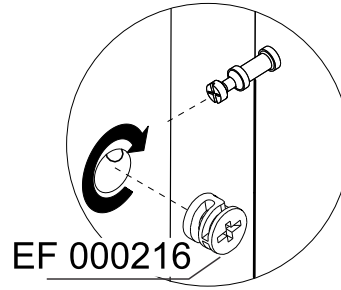

Por favor, observe a posição da ferragem EF 00025.  
 Please, note hardware EF 00025 position.  
 Por favor, notar la posición del herraje EF000025.

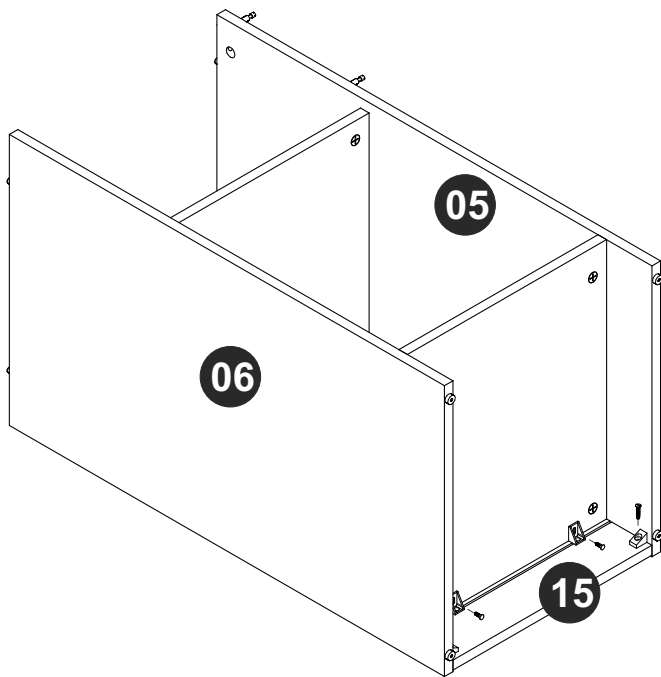

**PASSO 12 / STEP 12 / PASO 12**

Conecte a peça 15 utilizando as ferragens EF 000106 e EF 000107.  
 Connect piece 15 using hardwares EF 000106 and EF 000107.  
 Junte la pieza 15 utilizando los herrajes EF 000106 y EF 000107.

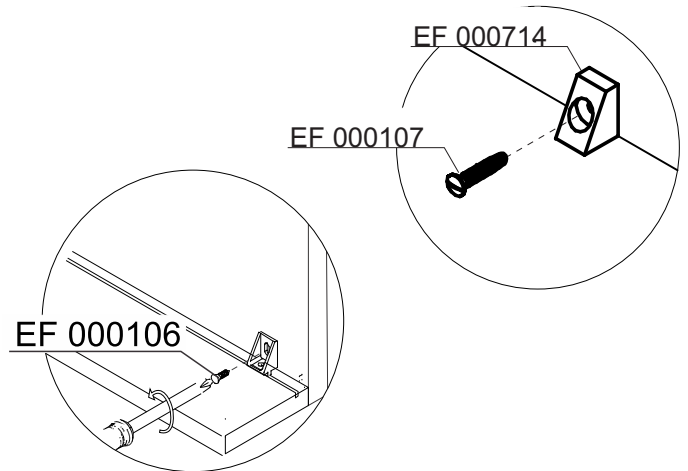

**PASSO 13 / STEP 13 / PASO 13**

Fixe as peças 17 e 18 utilizando a ferragem EF 000168.  
 Fix the pieces 17 and 18 using hardware EF 000168.  
 Fije las piezas 17 y 18 utilizando el herraje EF 000168.

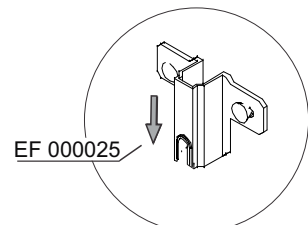
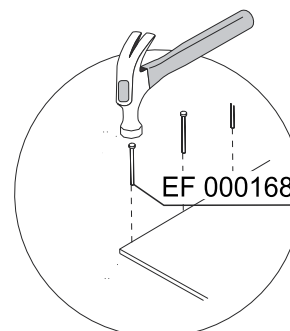
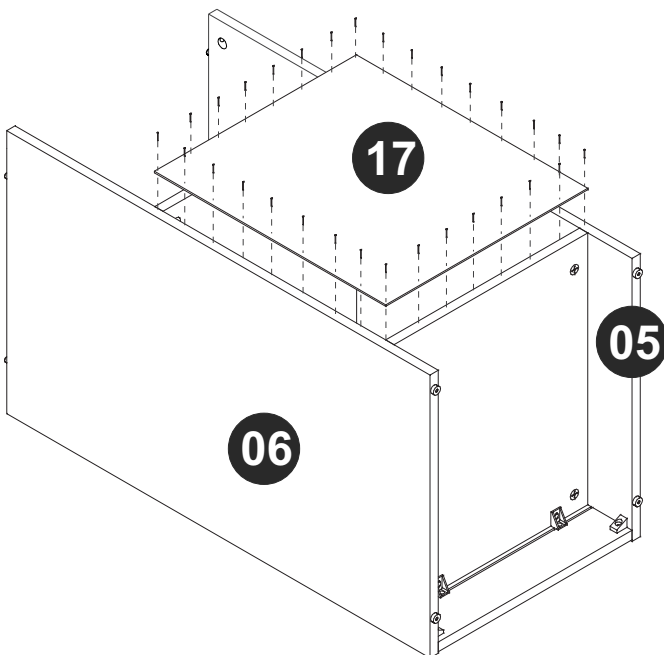

Por favor, observe a posição da ferragem EF 00025.  
 Please, note hardware EF 00025 position.  
 Por favor, notar la posición del herraje EF000025.

### PASSO 14 / STEP 14 / PASO 14

Conecte as peças 05, 09 e 11, insira a ferragem EF 000216 e gire para apertar.  
Connect pieces 05, 09 and 11, insert hardware EF 000216 and turn to tighten.  
Junte las piezas 05, 09 y 11, añáde el herraje EF 000216 y gire para apretar.

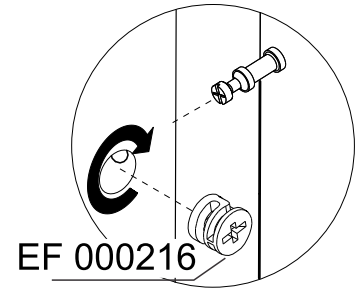
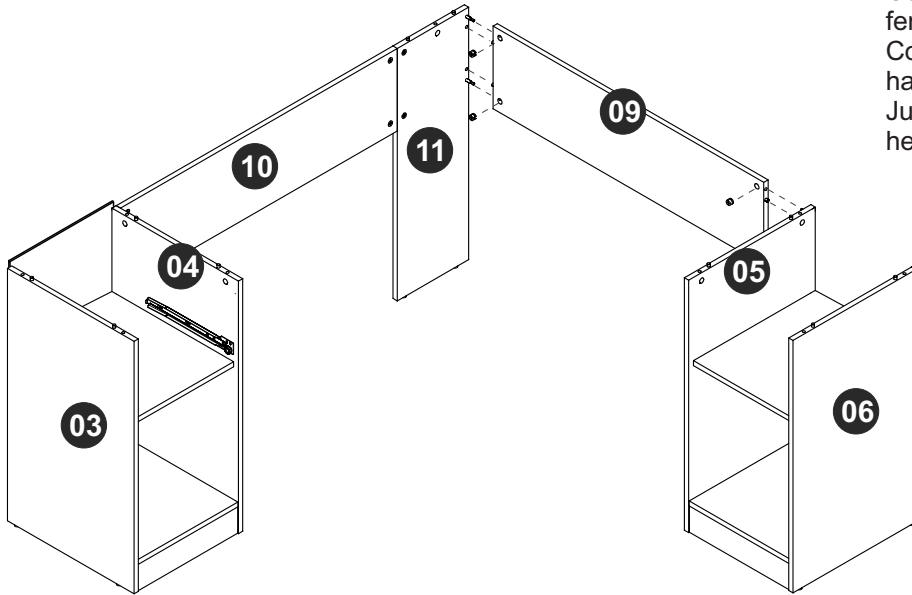

### PASSO 15 / STEP 15 / PASO 15

Conecte a peça 01, insira a ferragem EF 000216 e gire para apertar.  
Connect piece 01, insert hardware EF 000216 and turn to tighten.  
Junte la pieza 01, añáde el herraje EF 000216 y gire para apretar.

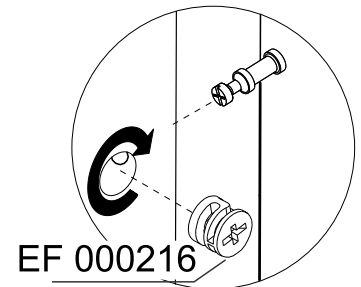
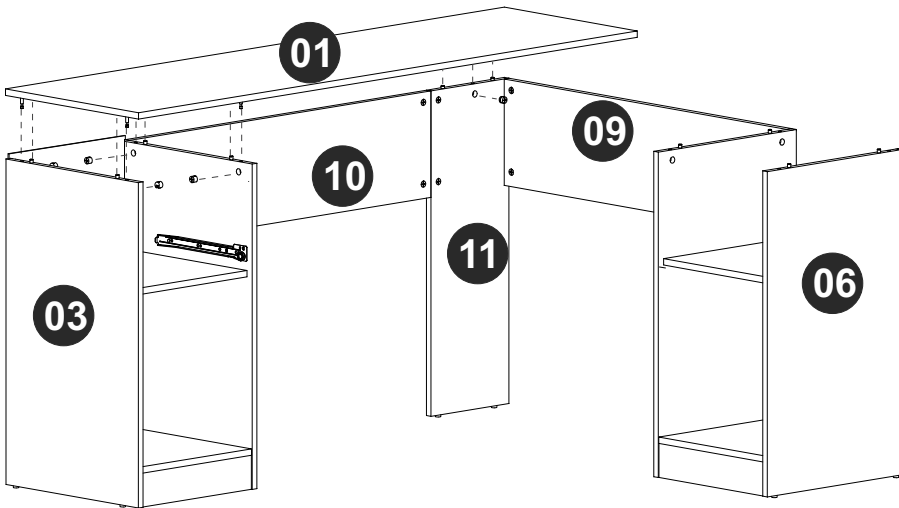

### PASSO 16 / STEP 16 / PASO 16

Conecte a peça 02, insira a ferragem EF 000216 e gire para apertar.  
Fixe as peças 01 e 02 com as ferragens EF 000069 e EF 000106.  
Connect piece 02, insert hardware EF 000216 and turn to tighten.  
Fix pieces 01 and 02 with hardwares EF 000069 and EF 000106.  
Junte la pieza 02, añáde el herraje EF 000216 y gire para apretar.  
Fije las piezas 01 y 02 con los herrajes EF 000069 y EF 000106.

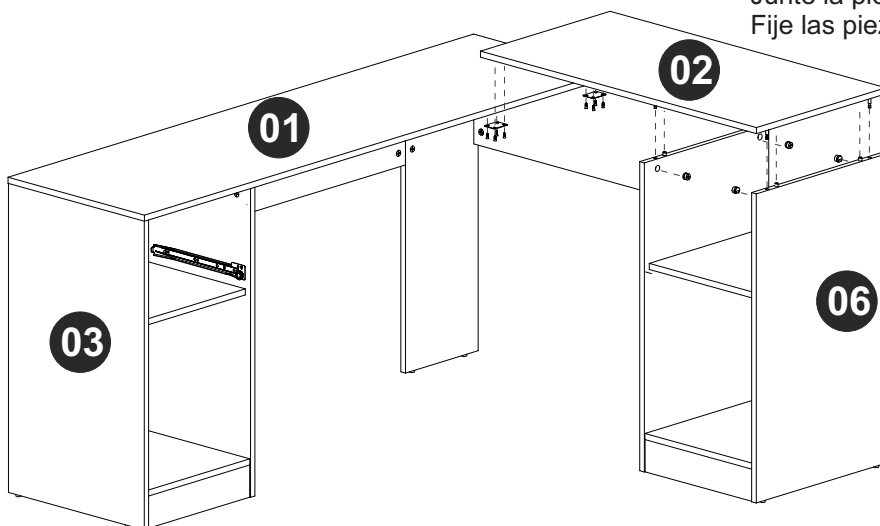

### PASSO 17 / STEP 17 / PASO 17

Conecte as peças 20, 21 e 22, insira a ferragem EF 000216 e gire para apertar.  
Connect pieces 20, 21 and 22 insert hardware EF 000216 and turn to tighten.  
Junte las piezas 20, 21 y 22, añáde el herraje EF 000216 y gire para apretar.

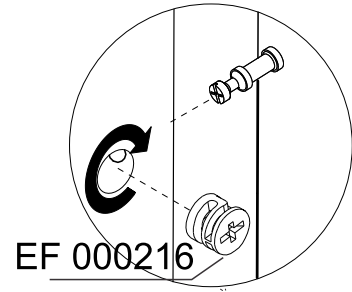
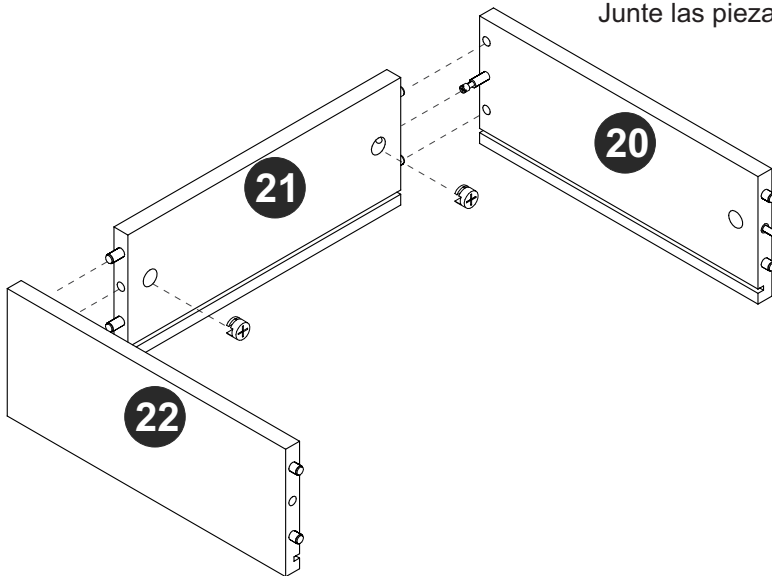

EF 000216



### PASSO 18 / STEP 18 / PASO 18

Encaixe a peça 16 entre os espaços específicos.  
Fix piece 16 through the specific space.  
Fije la pieza 16 entre los espacios específicos.

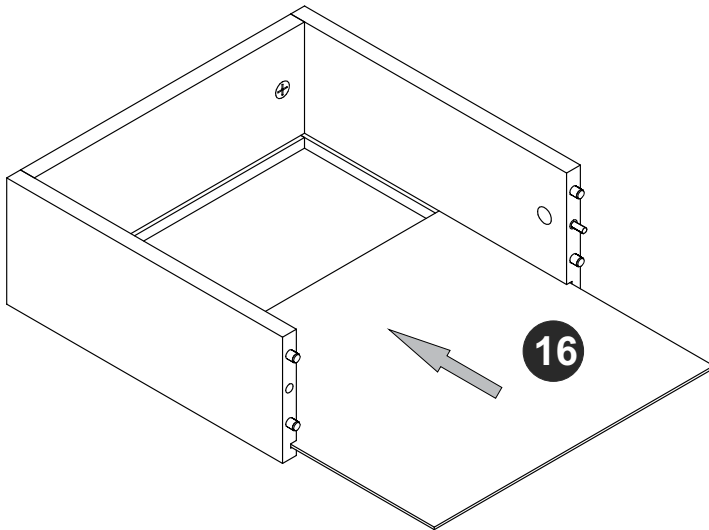

### PASSO 19 / STEP 19 / PASO 19

Conecte a peça 14, insira a ferragem EF 000216 e gire para apertar.  
Fixe o puxador utilizando a ferragem EF 000381.  
Connect piece 14, insert hardware EF 000216 and turn to tighten.  
Attach the handle using hardware EF 000381.  
Junte la pieza 14, añáde el herraje EF 000216 y gire para apretar.  
Fijel la manija utilizando el herraje EF 000381.

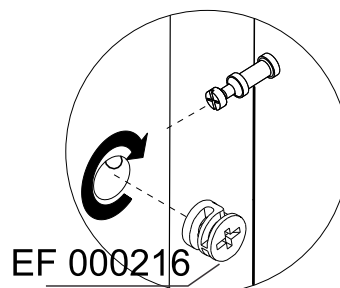
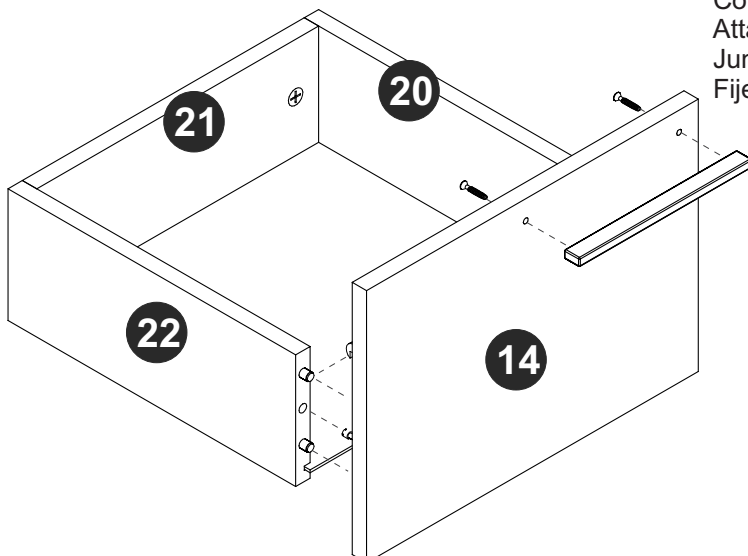

EF 000216

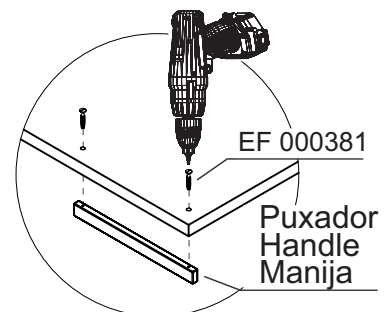

EF 000381

Puxador  
Handle  
Manija



## PASSO 20 / STEP 20 / PASO 20

Fixe as corrediças utilizando a ferragem EF 000106.  
Attach the drawer tracks using hardware EF 000106.  
Fije las correderas utilizando el herraje EF 000106.

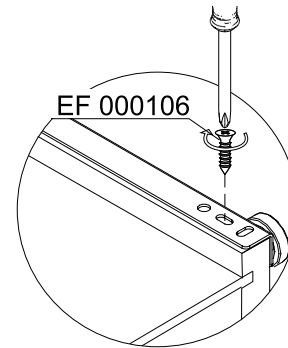
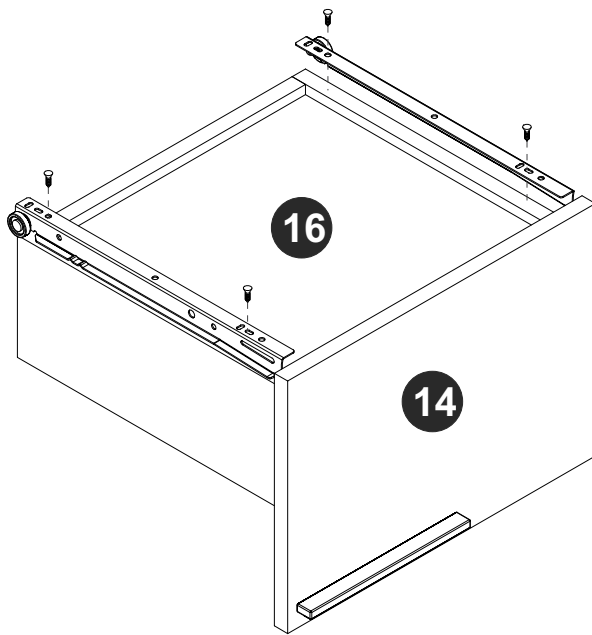

## PASSO 21 / STEP 21 / PASO 21

Fixe as peças 06 e 07 ao móvel montado.  
Fix pieces 06 and 07 at the assembled furniture.  
Fije las piezas 06 y 07 al mueble armado.

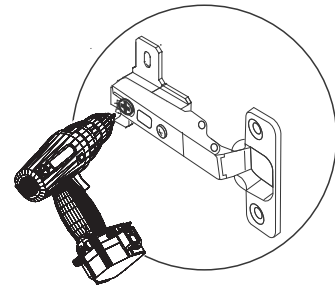
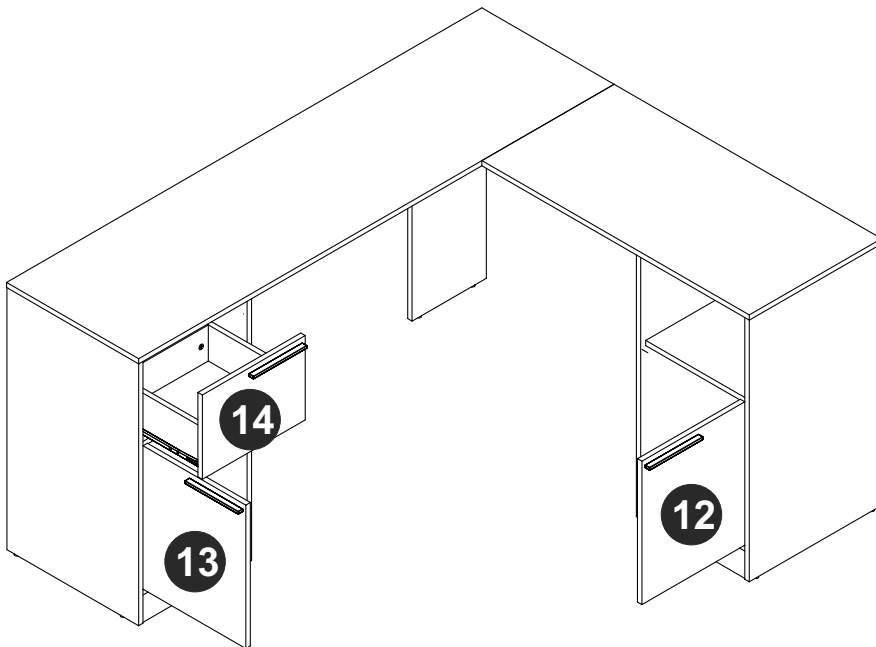

## PASSO 22 / STEP 22 / PASO 22

Use o giz para dar o acabamento final ao produto.  
Use the chalk to give the final finish on the product.  
Utilice la tiza para dar el acabado final al producto.

Use os tapa furos para cobrir os parafusos aparentes.  
Use stickers to cover apparent screws.  
Utilice los tapa huecos para cubrir los tornillos aparentes.

